

MINISTRY OF EDUCATION AND SCIENCE OF UKRAINE
NATIONAL TECHNICAL UNIVERSITY OF UKRAINE
“IGOR SIKORSKY KYIV POLYTECHNIC INSTITUTE”

BACHELOR DIPLOMA PROJECT

Organization, Requirements to Structure, Contents and Performance

Recommended by the Methodic Council Igor Sikorsky KPI as the manual book for applicants for a Bachelor Degree by the Educational Programs “Electronic Components and Systems” and “Electronic Devices and Equipment” for Specialty 171 “Electronics”

Kyiv
Igor Sikorsky KPI
2024

Bachelor diploma project. Organization, Requirements to Structure, Contents and performance [Electronic resource]: the manual book for the students by specialty 171 “Electronics” by the Educational Programs “Electronic Components and Systems” and “Electronic Devices and Equipment” / Igor Sikorsky KPI; compilers: V. Ya. Zhuykov, V. Ya. Romashko, E. V. Verbytskyi, L.M. Batrak – Electronic Text Data (1 file: 565 kb). – Kyiv: Igor Sikorsky KPI, 2024. – 59 p.

*The approval was granted by the Methodological Council of
Igor Sikorsky Kyiv Polytechnic Institute (minutes of meeting No. 8 dated June 20, 2024)
upon the submission of the Academic Council of Faculty of Electronics
(minutes of meeting No. 05/2024 dated May 20, 2024)*

Electronic Online Educational Publication

BACHELOR DIPLOMA PROJECT

Organization, Requirements to Structure, Contents and Performance

Compilers: *Valeriy Yakovych Zhuykov*, doctor of technical science, professor
Romashko Volodymyr Yakovych, doctor of technical science, professor
Verbytsky Evgen Volodymyrovych, doctor of technical science, professor
Batruk Larysa Mykolaivna, candidate of technical science, docent

Editor-in-Chief: *Safronov Pavlo Serhiyovych*, candidate of technical sciences, docent

Reviewer: *Berehun Viktor Serhiyovych*, candidate of technical science, docent,
docent of Acoustic and Multimedia Electronic Systems Department,
National Technical University of Ukraine “Igor Sikorsky Kyiv
Polytechnical Institute”

The manual book is intended to acquaint the students, which study by the Specialty 171 Electronics, educational programs "Electronic Components and Systems" and "Electronic Devices and Equipment" with the basic requirements for the preparation, structure, content and design of the diploma project of applicants of the first (bachelor) higher education level - bachelor diploma project. The publication was prepared at the Department of Electronic Devices and Systems.

CONTENT

BASIC DEFINITIONS AND CONCEPTS	4
GENERAL TERMS	6
1. PREPARATION FOR PERFORMING OF THE DIPLOMA PROJECT	9
2. STRUCTURE OF THE DIPLOMA PROJECT	13
3. FORMATION OF THE DIPLOMA PROJECT	18
3.1. Designing an explanatory note.....	18
3.2. Designing graphic documentation	24
3.3 Designing an abstract for work.....	32
4. DESIGN OF A MULTIMEDIA PRESENTATION	34
5. RECOMMENDATIONS REGARDING THE REPORT	40
6. ORGANIZATION OF THE DEFENSE OF THE DIPLOMA PROJECT	42
REFERENCES	45
Appendix A. Approximate theme of the diploma projects.....	47
Appendix B. Approximate structure of the diploma project by volume.....	48
Appendix C. Project statement	49
Appendix D. Title page.....	50
Appendix E. Tasks for completing the diploma project	51
Appendix F. Example of design of contents.....	53
Appendix G. An example of the design of an explanatory note page.....	54
Appendix H. Example of execution of the list of elements.....	55
Appendix I. General requirements for the diploma project.....	56
Appendix J. Feedback from the head of the diploma project.....	57
Appendix K. Review of the diploma project.....	58
Appendix L. Sample certificate about the reality of the diploma project.....	59

BASIC DEFINITIONS AND CONCEPTS

Diploma project is a qualification work intended for objective control of the degree of formation of skills and knowledge to solve typical activity tasks, which are mainly classified in the educational and qualification characteristics as organizational, managerial and executive (technological, operator) work functions.

The diploma project is a graduation independent work students, based on the protection of which the Examination Commission (EC) makes a decision on providing the student with a qualification bachelor's degree in a certain field of study. The project is considered a complex engineering and technical problem that is related to a solution tasks in the direction of improving the technical, economic and socio-ecological indicators of production.

A diploma project is drawn up from an explanatory note, graphic part, illustrative and (or) actual material and is design and technological documentation, the composition and scope of which is determined by the task for the diploma project.

The bachelor's qualification work is an independent, completed educational and scientific study that synthesizes the summary of theoretical and practical training within the normative and variable components of the educational and professional bachelor's training program in the relevant specialty.

Diploma (qualification) projects (works) are performed at the final stage of students' education and include:

systematization, consolidation, expansion of theoretical and practical knowledge of the specialty and its application in solving specific scientific, technical, economic, industrial and other tasks;

development of independent work skills and mastering research and experiment methods related to the topic of the project (work).

An educational program is a single complex of educational components (subjects of study, disciplines, individual tasks, control measures, etc.), planned and organized to achieve specified learning outcomes. (Article 1 of the Law of

Ukraine "On Education")

Technical specification (TS) is a document that establishes the main purpose, quality indicators, technical and economic and special requirements for the product, scope, stage of development and composition of the design documentation.

Specialty is a type of activity within the framework of one profession that requires specific knowledge, abilities and skills acquired as a result of education. A specialty is a set of theoretical and practical knowledge from a separate field.

An explanatory note is a textual description of the qualification project, which argues for the relevance, purpose and tasks of the work; uniqueness, market analysis, business plan, as well as available technical means, description of processes, list of used literature and sources, appendices.

The supervisor of the diploma project conducts consultations on the main sections, clarifies the graduation tasks, provides methodological assistance to the graduate student in the design of the explanatory note and graphic part, gives recommendations on the selection of scientific and technical, reference literature and other materials on the topic, monitors the progress of the graduation.

Professors, associate professors, senior teachers of the department, as well as researchers and highly qualified specialists in the field of electronics can be appointed as supervisors of diploma projects.

The project supervisors is approved by order of the rector based on the submission of the head of the department.

GENERAL TERMS

Preparation and defense of the diploma project for obtaining the bachelor's degree in electronics is the final stage of students' education of the first (bachelor's) level of higher education. The qualification work is performed in the form of a diploma project and is defended by the student at the end of the 8th semester of study.

In accordance with the Regulation about the examination board and about the examination commission and attestation of higher education applicants in Igor Sikorsky Kyiv Polytechnic Institute (<https://osvita.kpi.ua/node/35>), the bachelor diploma project is a qualifying work of a bachelor's degree of higher education student, intended for objective control of the skills formation level to solve typical activity tasks, which are assigned to engineering (design, construction, technological and operational) production functions.

The diploma project is the completed engineering development of the design object (system, device, technological process, computer programs, etc.) and the synthesis of the design object, which meets the requirements of the assignment for the diploma project; with detailed development of a certain functional part (element, node, subsystem, technological operation, etc.) taking into account the current level of development of the relevant field, achievements of science and technology.

The topic of the diploma project and the supervisor are assigned to the student by the graduation department no later than the 4th week of the 7th semester of study.

The purpose of writing a diploma project is to systematize and deepen students' theoretical knowledge in the field of electronics.

The diploma project has to:

- certify a certain level of preparedness of the student in the disciplines provided for by the educational program of the bachelor in electronics;
- to reveal the skills and abilities to use the acquired theoretical knowledge

in solving the problems of professional activity related to the design, research, testing, assembly, installation, maintenance, restoration and modernization of electronic devices and systems of various purposes;

- carry out practical calculations based on the actual data of the organization where the student underwent practice, as well as other practical data;
- prove the ability to draw up the results of theoretical studies, calculations and conclusions from one's own research in a complete document, use computer technology for this.

The diploma project has to be based on the knowledge and skills acquired during the study of disciplines during the entire period of study at the higher education institution (HEI), and may be partially based on the results of the course design and the material collected by the student during the pre-diploma internship. In it, it is necessary to show the ability to deeply and comprehensively research the questions, make reasonable and form specific proposals.

In addition, the diploma project aims to determine the general scientific, technical, professional and cultural levels of the student by controlling his knowledge and skills according to the educational program and assessing his ability to independently (according to typical methods) analyze the object, formulate tasks and conclusions, submit written and oral work material and defend it.

The diploma project in the department of electronic devices and systems should be complex in nature and combine the issues of the main disciplines that determine the preparation of a bachelor's degree in the specialty 171 Electronics. When completing the diploma project, the student has to demonstrate knowledge and skills at the level of the requirements of the National Framework of Qualifications, the standard of higher education for the first (bachelor's level) in the specialty 171 Electronics and the corresponding educational program. The student must demonstrate the ability and skill to solve typical tasks in the field of electronics, clearly navigate various types of modern electronic devices and systems, computer and microprocessor technology. If possible, individual

fragments of course projects and coursework completed in the fourth year of study can be components of the diploma project.

The diploma project is carried out individually according to the approved topic. It should be real, chosen taking into account the current state of the specialty, the labor market, the industry and regional context, scientific achievements of the department's scientists, leading researchers of Ukraine and the world.

The diploma project has to meet the following requirements:

- to be performed on an actual topic;
- be based on a thorough review of modern domestic and world literature, scientific articles and research results on the chosen topic;
- contain the formulation and solution of a specific engineering problem, in particular, design, construction, modeling, optimization and/or improvement of electronic devices, devices and systems;
- to be performed with the use of modern electronic components, information and communication technologies, software, computer and microprocessor technology;
- have positive feedback from the manager and the reviewer;
- contain all the necessary structural elements, specific quantitative and qualitative conclusions, proposals for further development, a list of used literary sources.

1. PREPARATION FOR PERFORMING OF THE DIPLOMA PROJECT

The stages of the diploma project preparation are shown in fig. 1.

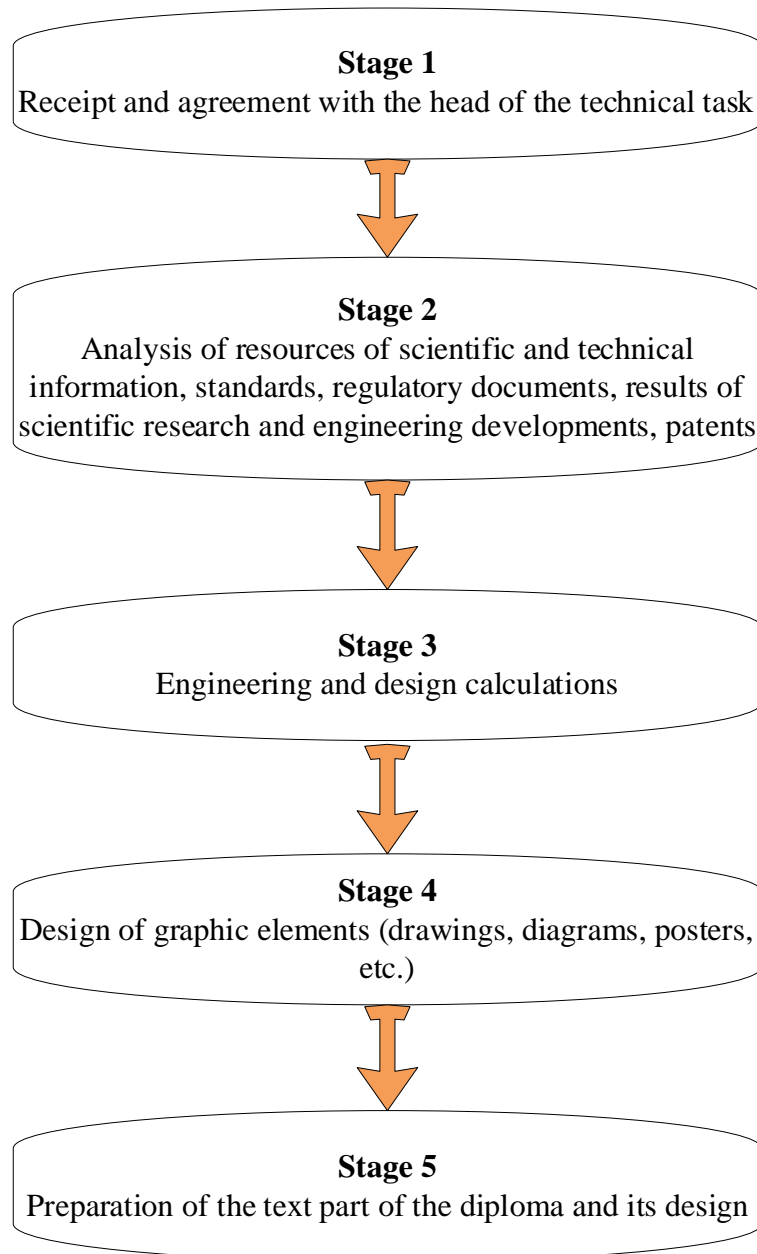

Fig. 1. The stages of the diploma project preparation

Preparation for writing a diploma project begins with choosing a topic.

The student has the right to independently propose a topic of the diploma project that does not relate to the subject taught at the department. At the same time, it is necessary to justify it, to determine the purpose, subject and object of research, compliance with the specialty 171 Electronics, and to propose an approximate plan for

writing a diploma project.

The diploma project, carried out on a typical topic, can be considered as part of a complex qualified work of an interdisciplinary nature (authors of such a work can be several, but no more than three people) in agreement with the leading teachers of the department.

Development of the Technical specification for the diploma project is carried out by the diploma supervisor.

For complex works, the student's personal contribution to the development must be clearly indicated in the Technical specification. At the same time, no more than 30% overlap in the content of works is allowed.

Assignments for a diploma project may include research, design, calculation, and experimental work. The content of the diploma project can include: analysis and improvement of the technical functions of the device, device or technological process; design of individual construction modules; design of technological processes and their elements; analysis of the physical principles of the functioning of modules of radioelectronic devices, electronic, microelectronic and nanoelectronic devices; execution of technical calculations, preparation of design and technological documentation, conducting and analyzing the results of experiments, proposals for improvement, modernization or new technical solutions; development and construction of devices, devices and systems with improved technical and economic indicators; calculation of processes in electronic devices and systems with analysis of the received data; simulation of the operation of devices, devices and systems and analysis of the results of such simulation; development of specialized software for solving complex engineering, research and/or methodological problems in electronics.

The object of the analysis in the diploma project can be various objects of electronic and microprocessor equipment: devices of power conversion equipment, radio equipment, electronic computing devices, electronic equipment of various purposes, means of communication, medical and biotechnical electronic devices and systems, electronic equipment for scientific research, control and measurement electronic equipment, electronic and optoelectronic means of automation of

production, security electronic systems, specialized software. Possible topics of bachelor's theses are given in Appendix A.

It is advisable to formulate the topic of the diploma project at the beginning of the 4th year (after appointment of the supervisor). The subject of the diploma project is specified in the university order at the beginning of the 8th semester.

The department approves the topics and assigns each student a supervisor from among the department's teachers or practitioners of the relevant profile. The topics of and supervisors of diploma projects are approved by the department in accordance with the established procedure. When choosing and approving topics, duplication is not allowed.

Having chosen a topic, the student has to clearly define the purpose and tasks of the diploma project, the sequence of its writing, select the appropriate modern scientific literature, regulatory and methodical materials. Qualified help in this can be provided by teachers and other employees of the department. After studying literary sources and normative materials, the student begins to draw up a work plan.

Drawing up a plan is one of the most important stages of preparatory work. The successful completion of the diploma project depends on its correctness, clarity and logic. The plan should reflect the essence of the chosen topic, the direction of its research, the setting of individual questions, the use of analysis methods. After independently drawing up two or three options of the plan, it is recommended to contact the supervisor. After discussing the options, a work plan and the content of the diploma project are formed. After agreeing on the plan and structure of the diploma project, the student together with the supervisor draw up a Technical specification for its implementation according to the form specified in Appendix E. The Technical specification is approved by the head of the department. The assignment form also includes a calendar plan for the completion of the diploma project. After that, the student starts the diploma project.

During the diploma project preparation, the student has to regularly (at least once a week) report to the supervisor, about which the supervisor informs the head of the department upon request. In case of non-fulfilment of this requirement without

valid reasons, the student may be excluded from the completion of the diploma project and expelled from the university for not fulfilling the educational plan.

At the final stage (the last week of the term set aside for writing the diploma project), the department will organize a check of the compliance of the text of the diploma project with the task and design standards. The inspection is carried out by a commission approved by a verbal or written order of the head of the department.

In addition to the supervisor, the head of the department may appoint employees of the department for consultations on individual sections of the diploma project.

2. STRUCTURE OF THE DIPLOMA PROJECT

The diploma project is written in Ukrainian or English and consists of an explanatory note and at least 3 sheets of graphic material.

The explanatory note is made on one side of sheets of white A4 paper (297 mm x 210 mm) in accordance with GOST 2.104–2006 (f. 2 and 2a) with the following margins: left – 30 mm, right – 15 mm, upper – 20 mm, the lower one – 20 mm. The volume of the diploma project should be within 50-70 pages of printed text (font Times New Roman 14, line spacing 1.5), not including the list of references and appendices. The diploma project has to be printed without the use of empty lines between subsections, formulas, figures and other elements of the text, and non-standard abbreviations and abbreviations of words that are not decoded in the section of the list of conventional designations. As a rule, the department recommends the following structure of the diploma project (see Appendix B): introduction, the main part, which consists of two to three technical sections, conclusions, a list of used literature, appendices, and an abstract.

It is necessary to try to evenly present the material in sections, and in the middle - by subsections. Some deviations in the volume of certain sections are allowed, but it is not recommended that the volume of one section should be 50 percent or more of the total volume of the diploma project. The content of the diploma project should be presented succinctly, without repetitions, unnecessary deviations from the main topic, description, long mathematical statements that oversaturate the text. The style of presentation of the material should correspond to the scientific and technical style.

The explanatory note contains:

- project statement;
- title page;
- Technical specification;
- annotations in Ukrainian and English languages;
- content;

- a list of conventional designations, symbols, units, abbreviations, terms (if necessary);

- introduction;
- main part;
- conclusions and recommendations;
- references;
- applications (if necessary);
- abstract.

Project statement

The first page is a description of the project, which is carried out in accordance with Regulations about the examination commission and attestation of higher education applicants in Igor Sikorsky Kyiv Polytechnic Institute [3] (see Appendix C).

Title page and task

The form of the title page and the task page is performed in accordance with the recommendations of the educational and methodical department of Igor Sikorsky KPI [3]. The form of the title page is given in Appendix D and E.

Abstracts

Abstracts are made on a separate sheet without a frame in Ukrainian and English languages. Abstracts should briefly reflect the content of the diploma project, provide concise information about the object of development, include specific data on the technical characteristics of the development, as well as brief conclusions regarding the field of application.

Content

The first page of the contents is made on a sheet in accordance with GOST 2.106-96 (f. 2 and 2a) (see Appendix F).

The content should include all sections and subsections of the main part, conclusions, a list of references, appendices, which are in the explanatory note with page numbers. The title page and abstracts are not included in the table of contents. The content should correspond to the headings in the text of the diploma project.

Introduction

The introduction, as well as all sections, starts on a new page. The introduction substantiates the relevance of the topic of the diploma project, and indicates its place in modern research. Admission includes:

- characteristics of the object of development;
- purpose of development;
- tasks to be solved;
- a general description of the methods of analysis or research used in the diploma project.

Main part

The main part should contain:

- review of the literature on the subject of the diploma project;
- analysis of the Technical specification;
- project part.

The literature review should include an analysis of modern technical and scientific sources on the topic of the diploma project, in which it is necessary to show the relevance of the task, determine the place of development, the field of application, the results of a comparative analysis with known technical and/or software solutions. The list of used sources have to contain a sufficient number of modern sources (not older than 5 years).

The analysis of the Technical specification includes the main areas of circuit-technical and design-technological development solutions on the chosen topic. The amount of necessary calculations is determined by the supervisor of the diploma project, taking into account the topic and specifics of the project.

Conclusions and recommendations

The conclusion summarizes the development. Conclusions are consistent with the purpose, declared tasks and should contain both ascertaining and constructive parts, qualitative and quantitative results.

Conclusions on the work should include:

- general analysis of the obtained results and their comparison with analogues;
- generalization of partial conclusions of sections;
- suggestions and recommendations regarding the use of the obtained results, the need for additional or parallel research.

References

The bibliography in the diploma project is placed in accordance with the established rules and consists of a list of literature and other sources used in the preparation of the diploma project. The rules for compiling a bibliographic description are regulated by the state standard DSTU 8302:2015 "Information and documentation. Bibliographic reference. General requirements and rules of drafting".

The bibliographic description, as a rule, is written in the language of the text of the publication, following the rules of modern orthography. Abbreviations of words and phrases are allowed in accordance with the state standard DSTU 3582:2013 "Information and documentation. Bibliographic description. Abbreviations of words and phrases in the Ukrainian language. General requirements and rules".

The list of used sources should include fundamental, educational literature, scientific and technical publications, articles in scientific journals, links to Internet sources. It is recommended to use literature published in the last 5 years. References to fundamental monographs, important scientific articles, textbooks and training manuals published earlier are allowed, provided they are justified, and their number is less than the number of modern sources.

Appendices

Appendices to the explanatory note in the diploma project may contain additional materials:

- lists of elements for electrical circuits;
- listings of developed computer programs;
- results of calculations on a computer.

Appendices can also contain bulky tables, complex diagrams, algorithms for solving problems or modeling, mathematical statements that interfere with the perception of the material of the main part.

Graphic documentation of the diploma project

The presentation part is also prepared for the defense of the diploma project:

- in the form of graphic documentation in A1 formats;
- in the form of a presentation for demonstration on the screen.

The graphic material of the diploma project should be presented in the form of drawings and posters reflecting the main provisions and results. The composition and volume of graphic material is determined by the supervisor of the diploma project. The recommended amount of graphic material is 3-4 sheets. Examples of graphic documents of the diploma project are:

- electrical structural scheme;
- the electric functional scheme;
- basic electrical scheme;
- block diagrams of software algorithms;
- posters that illustrate the functioning of the development (calculated ratios, diagrams, graphs).

3. FORMATION OF THE DIPLOMA PROJECT

3.1. Making up of the explanatory note

Diploma projects are drawn up in accordance with DSTU 3008:2015 "Information and documentation. Reports in the field of science and technology. Structure and rules of design". Diploma projects in the field of engineering have to additionally take into account the requirements of the Unified Design Documentation System.

The results of the performed research are presented in the diploma project based on the following requirements:

- meaningfulness and specificity of presentation of the material;
- logic, systematicity and consistency;
- selection of individual paragraphs and sentences in the text, as too large fragments do not contribute to proper understanding of the presented material;
- completeness of presentation of each opinion;
- absence of spelling, stylistic, grammatical, logical and other errors, tautology;
- lack of scanned information (drawings, tables, text fragments), illustrations of poor quality;
- proper design of the diploma project.

The explanatory note is made on sheets with a frame of the working field in accordance with GOST 2.106 - 96 (f. 2 and 2a) and the main inscription, in accordance with GOST 2.104 - 2006 "Main Inscriptions".

The main inscription on the A4 format is placed in the lower right corner of the sheet. Fig. 3.1 shows shows an example of the main stamp for the following sheets.

					DP.DS02.012.000 EN	Pages
Cn.	Pag..	№ docum	Sign.	Date		2

Fig. 3.1

The following structure of designation of the main design document (diploma project) is recommended – DP.DS-02.12.000 EN

where: DS02 - number of the student's academic group;

12 – number of the student in the group list;

000 – three-digit numerical registration number;

EN – document code (explanatory note).

Text formatting

Text formatting is performed according to the following requirements:

- the headings of the structural parts of the diploma project "CONTENTS", "INTRODUCTION", "CHAPTER", "CONCLUSIONS", "LIST OF REFERENCES", "APPENDICES" are written in capital letters and placed symmetrically above the text without hyphenation and without a period at the end;

- headings of subsections are written in lowercase letters from the first capital letter and placed in a paragraph without a period at the end;

- the headings of clauses and subsections within the subsection are printed in small letters (except for the first capital letter) from the paragraph indentation to match the text in bold, with a full stop at the end;

- the distance between the title of the section and the following text should be equal to 3-4 intervals, that is, with a line interval of 1.5, the text should begin after one missed line. The same distance should be between the end of the text and the title of the subsection, the title of the section and the subsection (see Appendix G);

- the line spacing in the title of the section or subsection must be the same as in the text of the diploma project;

- paragraph indentation should be equal to 1.25 mm;

- it is not allowed to place the name of the subsection, item and sub-item at

the bottom of the page, if only one line of text is placed after it;

- items and sub-items may not have headings and must begin with a paragraph;

- a dot is not placed after the number of the section, subsection, item, sub-item, and the text in capital letters follows;

- the page number is placed in a frame in the upper corner without a period;

- a new chapter begins with a new sheet, regardless of how the previous chapter ended;

- formulas are printed in MathType formula editors;

- formulas are highlighted from the text and centered;

- numbering should only be those formulas to which there is a reference in the subsequent text, otherwise it is not recommended to number the formulas;

- formulas are numbered with numbers to the right of the formula (alignment of the formula number on the right edge of the page) in round brackets with Arabic numerals within the section. The number of the formula consists of the number of the section and the serial number of the formula, separated by a dot;

- after the formula, an explanation of each symbol is required, the first explanation begins with the word "where", for example:

$$\sigma = \frac{r_L + r_{dyn}}{R_{ld}}, \quad (3.1)$$

where r_L – resistance of inductivity; r_{dyn} – dynamic resistance of diode; R_{ld} – resistance of load.

- the font size of the formula should be the same as the font size of the main text;

- reference to the corresponding formula in the text is made by quoting its number in round brackets, for example, (3.1);

- a reference to a literary source is made by quoting its number in square brackets in the text, for example, [3];

- references to figures and tables are made by quoting their numbers after the words "Fig." and "Table" respectively, for example, Fig. 3.1;

- when formatting the text, it should be remembered that formulas and numbers are the words of sentences, and all the rules of syntax apply to them. So, if the sentence ends with a formula or a number, a dot should be placed after them;

- illustrations (photos, diagrams, graphs, maps) are marked with the word "Fig." and are numbered consecutively with Arabic numerals within the section, with the exception of the illustrations provided in the appendices. The drawing number should consist of the section number followed by a dot of the serial number of the drawing (for example, Fig. 1.2). The figure number is printed in 12 font size;

- illustrations and tables are given after the mandatory first reference to them in the text or at the beginning of the next page in case the figure does not fit on the page with the first reference after this reference. Several illustrations or tables can be placed on one sheet;

- drawings have to have a title and, if necessary, additional explanatory data. The title is placed under the figure, the explanatory data under it are printed in font 12 (see Fig. 3.2 and Appendix G);

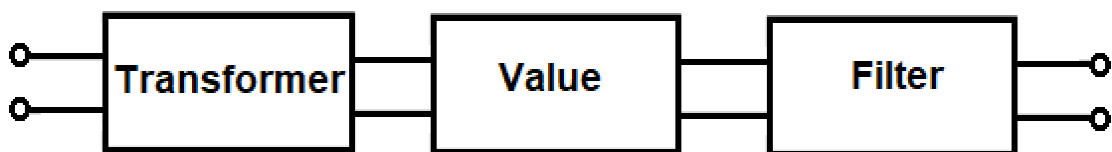

Fig. 3.2 The picture title with capital letter without dot at the end

– headings of tables, graphs, diagrams have to correspond to the content of the illustrated material. In the tables containing the values of physical quantities;

– tables have to have titles that are printed in small letters (except for the first capital letter) with font size 12 and placed above the table in the middle;

– the title should be short and fully explain the content of the table;

– headings of table graphs begin with a capital letter, and sub-headings with a lower-case letter, if they form one sentence with the heading;

– if it is necessary to number indicators, parameters or other data, serial numbers are indicated immediately before their names;

– tables are numbered with Arabic numerals. The table number consists of the serial number of the section and the serial number of the table, for example, Table 3.1;

- if there is only one table in the text, it is not numbered and the word "table" is not written.

- it is allowed to rotate the table by 90°, while the header is placed in the place where the pages are stitched;

Table 3.1

Table title with capital letter without dot at the end

№	Indicator	Value
1.	Voltage, V	220
2.	Frequency, Hz	50

– each table, usually, should be placed on one page. Large tables that do not fit on 1-2 sheets should be placed in an appendix. Such tables have a separate numbering in the sequence in which they are reinforced in the text;

– a table with a large number of rows can be extended to another sheet, while on the right side they write "Continuation of the table." and indicate the table number;

– references in the text of the work to literary sources should be indicated by the serial number/numbers in the list of references separated by two square brackets, for example, "... according to research results [1 - 9],...";

– when citing sources, the following rules should be followed:

- the citation text begins and ends with quotation marks and is given in the grammatical form in which it is presented in the source, preserving the features of the author's writing;

- the citation has to be complete, without arbitrarily shortening the author's text and without intentionally distorting the author's thoughts. Omission of words, sentences, paragraphs when quoting is allowed and is marked with three dots. They

are placed anywhere in the citation (at the beginning, inside, at the end). If the omitted text was preceded or followed by a punctuation mark, it is not saved;

- each citation has to be accompanied by a reference to the source, a serial number is given in the list of literary sources inserted in square brackets;

- in the case of indirect citation (representation of opinion), which gives a significant saving of the text, one should be extremely precise in expressing the author's thoughts, be specific in evaluating his results and give appropriate references to the source;

- citations should organically fit into the context of the work;

- it is allowed to refer to sources in footnotes, while the design of the reference has to correspond to its bibliographic description according to the list of references with the number indicated;

- literary sources can be placed in the order of references in the text of the diploma project or alphabetically. Sources should be written in the language of the publication and comply with the current standard of Ukraine.

- the literary sources used in the diploma project are placed as follows: monographs, books, brochures firstly follow surname and initials of the author (authors or compilers, if there are no more than three of them), title of the work, place of publication, publisher, year of publication; for works used from the collections, journals and newspapers, firstly follow surname and initials of the author, name of the article (work), name of the source according to the details of the title page, year, number, page of the beginning of the article (work);

- appendices are drawn up as a continuation of the diploma project on the following pages or in the form of a separate part, placing them in the order of appearance of references in the text of the work. Each application must start on a new page;

- the appendix has to have a title printed at the top in small letters with the first capital letter symmetrically relative to the text of the page. In the middle of the line above the title, the word "Appendix" and a capital letter indicating the appendix are printed in small letters from the first capital letter. Appendices should

be marked consecutively with capital letters of the English alphabet for example, appendix A, appendix B, etc.;

- if there is only one appendix, it is designated as appendix A.

- the text of each appendix, if necessary, can be divided into sections and subsections, which are numbered within each appendix. In this case, each number is preceded by the designation of the appendix (letter) and a dot, for example, A.2 - the second section of appendix A;

- illustrations, tables and formulas, which are placed in the appendices, are numbered within each appendix, for example: Fig. D.1.2 – the second figure of the first section of Appendix D; formula (A.1) is the first formula of Appendix A.

3.2. Drawing up graphic documentation of the diploma project

3.2.1 General rules

Illustrative materials (graphic materials, presentations, experimental samples, models) are submitted for protection. Graphic material is drawn up in accordance with DSTU HOST 2.104:2006. Yedyna systema konstruktorskoi dokumentatsii. Osnovni napysy. Schemes must be executed in accordance with the requirements of the GOST 2.701 - 2008 and DSTU GOST 2.702:2013).

Paper copies of posters and drawings are printed on A1 paper (size 594mm x 841mm).

Each design document must have a frame of the working field and a main inscription, which includes general information about the depicted objects, shapes, sizes, content, the order of filling in the main inscriptions and additional columns to them in the design documents is established by DSTU 2.104-2006 "Main Inscriptions".

The main inscription on the A1 format is placed in the lower right corner of the sheet. An example of the execution of the main stamp of graphic documents is shown in fig. 3.3. and 3.4.

					DP DC02. 003. 001. E3					
					<div style="border: 1px solid black; padding: 2px; display: inline-block;">1</div> The subject of the diploma project. trical schematic diagram	Лит.		Mass	Scale	
Con.	Sheet	Name	Signat	Date		D	W	Б		
Developed				01.06.24						
Check.				06.06.24						
NTN/cont										
						Sheet 1		Sheets 2		
N/contr.					<i>"Igor Sikorsky KPI" FFI FPS</i>					
Confir				10.06.24						

Fig. 3.3 For the first sheets

					DP DC02. 003. 001. E3				Sheet
Con.	Sheet	№ doc	Signatu	Date				2	

Fig. 3.4 For the following sheets of drawings and diagrams

The structure of the designation of the graphic document is the same as that of the explanatory note, only the code of the document changes, for example, E1 - the code of the electrical structural scheme, E2 - the code of the electrical functional scheme, E3 - the code of the electrical principle scheme, TD - the code of the theoretical drawing (graphs, formulas, calculations, photos, etc.).

The name of the scheme is entered in column 1 (Fig. 3.3) of the main inscription after the name of the product for which the scheme was developed in a smaller font. The name of the product should be written in the nominative singular, putting the noun first. Hyphens are not used in titles, and a period is not placed at the end.

References to the graphic part are made in the form: "... given on the scheme DP. DS02.00.000.E3".

Below are the basic rules for the execution of some types of schemes that are mandatory in the graphic part.

3.2.2 Electrical structural scheme

The electrical structural diagram defines the main functional parts of the product (elements, devices, functional groups), their purpose and connections.

All functional parts on the diagram are depicted in the form of rectangles or conventional graphic symbols (CGS). When displaying rectangles, names, conventional designations or numbers of functional parts are written in the middle of the rectangles. Conventional designations and numbers must be deciphered on a free field of the scheme in a table of arbitrary form. Positional designations are written above the CGS or to the right of them.

Rectangles or CGS on the diagram are connected by electrical communication lines, on which arrows indicate the direction of the work process. The structural diagram should give an idea of the progress of the work process in the direction from left to right, from top to bottom.

If there are many functional parts, the latter are replaced by squares with sides in multiples of 12 mm. In this case, instead of names, types and designations, serial numbers are placed to the right of the image or above it, as a rule, from top to bottom in the left-to-right direction, and deciphered in a table of arbitrary shape, which is placed on a free field of the scheme.

On the scheme, it is recommended to place explanatory inscriptions, diagrams, tables, parameter indications at characteristic points (magnitudes of currents, voltages, shapes and sizes of pulses), mathematical dependencies, etc.

3.2.3 Electrical functional scheme

The functional scheme reflects the processes that occur in individual functional circles of the product or in the product as a whole. Compared to the structural scheme, this scheme reveals the functions of individual elements or devices in more detail. The diagram shows all the functional parts of the product and the main connections between them.

Functional parts on the diagram are depicted in the form of UGP according to state standards. It is allowed to depict individual functional parts, on which there is no CGS, in the form of rectangles, as well as to reveal them to the level of schematic diagrams.

It is allowed to combine functional parts into functional groups, which are

highlighted on the diagram by dash-dotted lines. Each selected group is assigned a name or convention.

The scheme should indicate:

- for each functional part depicted by a rectangle, its name or conventional designation written in the rectangle;
- for each functional part or element depicted by the UHP, a positional designation.

If the functional diagram is used together with the principle one, then the positional designation of elements and functional parts on these documents must be the same. In this case, the list of elements is not developed for the functional scheme, since they use the data of the principle scheme.

If the functional scheme is developed independently (without a principle one), then the positional designation of elements and functional parts is indicated according to general rules and a list of elements is developed.

On the functional diagrams, it is recommended to indicate the technical characteristics of the functional parts, diagrams, signal parameters, etc., next to the graphic designation or on the free field of the diagram.

3.2.4 Basic electrical scheme

The basic electrical diagram is the most complete diagram of the product and gives a detailed idea of the principle of its operation.

The diagram shows all the component parts of the product and the connections between them, as well as the elements that end the input and output circuits (connectors, clamps, etc.).

The scheme should be performed for the mode when the product is in the off state. If the mode is different, the mode for which the scheme is executed is indicated on the scheme field.

All elements and connections between them on the diagram are depicted using UGP in accordance with current state standards and placed in such a way that the diagram is the most visual, easy to read.

Schemes are recommended to be executed in a linear way: conventional graphic designations of devices and their constituent parts, which are part of one circle, are depicted sequentially one after the other in a straight line, and separate circles in the form of parallel horizontal or vertical strips.

Elements that are partially used in the design may not be depicted in their entirety, but only those parts that are used.

The outputs of the unused parts of the UHP should be drawn short.

It is allowed to merge several electrically unconnected communication lines into one line. At the same time, each line at the point of confluence at both ends is marked with conventional designations (digital or alphanumeric).

The diagram allows you to indicate the characteristics of the input circuits of the products (frequency, voltage, current, resistance, etc.), as well as the parameters to be measured on the control contacts. Inscriptions, signs or graphic designations, which must be applied to the product, are placed next to the corresponding elements in quotation marks.

It is allowed to indicate the addresses of the external connections of the input and output circuits of this product, if they are known.

Conventional graphic designations of input and output elements - connectors, boards, etc. is allowed to be replaced by tables of arbitrary sizes. Tables are assigned positional designations of the elements they replace.

All elements on the diagram must have an alphanumeric positional designation (PP), which is written only in capital letters of the Latin alphabet and Arabic numbers, in the same font, in one line without gaps (R1, C25, ...), to the right of the UGP or above them. Serial numbers are assigned in the top-down, left-right direction within the element view. When performing the scheme on several sheets, the serial numbers continue. Type and number are mandatory parts of UGP.

When combining elements into functional groups, element numbers are placed within the group and numbers are assigned to the group.

It is allowed to place on the scheme field:

- instructions on brands, cross-sections and colors of wires and cables that

connect elements, devices, functional groups;

- instructions on specific requirements for the electrical installation of this product.

UGP can be performed in a combined or separate way:

- with the combined method, the component parts of the element are depicted on the diagram as they are placed in the product, i.e. together;

- in the distributed method, the component parts of the element are placed in different parts of the scheme as determined by the sequence of the product's work process. At the same time, the serial number of the part of the element is added to the number, separated by a dot (DA1.2).

If the circuit has UGP microcircuits, on which the terminals for connecting the power supply are not indicated, then the table is performed on the free field of the circuit (see Table 3.1).

Table 3.1.

Table of connection of microcircuits to power buses

Power bus	Outputs of microcircuits		
	<i>DD1, DD4</i>	<i>DD2</i>	<i>DD3, DD5 ... DD8</i>
+ 5 B	20	16	14
0 B	10	08	07

Each scheme must have a list of elements (LE), in which all the elements shown on the scheme are recorded. The shape and dimensions of LE must comply with the interstate standard GOST 2.701 - 2008.

LE is placed on the first sheet of the scheme or executed in the form of an independent document. An example of the list of elements on the electrical principle diagram is given in Appendix H.

Fill in LE by groups of elements in alphabetical order.

In the column "*Name*" should be indicated: the type of element, its parameters and designation of the document according to which it is used (TU, DSTU).

In the first case, it is placed above the main inscription, but no closer than 12

mm (the continuation is to the left of the main inscription). In the second case - on sheets of A4 format with the main inscription according to form 2 and placed in the appendices of the explanatory note. At the same time, the name of the product is indicated in column 1 of the main inscription, and "*List of elements*" below.

If the scheme includes functional groups, then the elements that are not included in the group are first recorded in the LE, and then the number is indicated. functional group, the name of the group (underlined) and their number. Next, write down the elements that are included in the group according to the above rules.

3.2.5 Rules for execution of block diagrams of algorithms

A block diagram of an algorithm is a graphic representation of the logical structure of an algorithm, where each stage of information processing is depicted in the form of conventional graphic symbols (blocks).

Block diagrams of algorithms reflect the sequence of actions and, in general, consist of an appropriate number of conventional graphic symbols (symbols) of the main operations, a short explanatory text, and connecting lines that indicate the order of actions.

Symbols are drawn with a solid main line, data flow or control lines are drawn with a thin one.

The shape of the symbols and their orientation must comply with the international standard GOST 19.701 - 90.

The vertical size of symbols (a) must be selected from a series of numbers that are multiples of 5, starting with 10. The horizontal size (c) should be equal to 1.5a or 2a.

Within one scheme, it is allowed to use no more than two adjacent sizes of a series of numbers that are multiples of 5.

Symbols in the scheme should be placed evenly.

The text in the middle of the symbols is placed parallel to the main inscription, regardless of the direction of the flow. The text is typewritten with 1 space. Abbreviations of words are not allowed, except for generally accepted ones.

For explanations, or when there is not enough space for text in the middle of the symbol, use the comment symbol.

The flow lines must be parallel or perpendicular to the lines of the frame of the working field and approach the symbols or depart from them - from the left, right, top, bottom towards the center of the symbol.

The distance between parallel flow lines is not less than 3 mm, between other symbols is not less than 5 mm.

The direction of the flow is depicted by arrows on the flow lines near the symbols to which they come. It is allowed not to indicate the arrow, if the flow direction is top-down, left-right. Arrows must point in other directions.

Flow lines should cross and bend only at an angle of 90°. Change of direction at crossing points is not allowed.

In order to reduce the number of intersections of flow lines, the connection symbol is used. In electrical diagrams, an arrow is used for this, in program diagrams - a circle with a diameter of 0.5a, in the middle of which indicate the connection number.

If the scheme does not fit on one page, then the transition to other pages is performed by the connection symbol together with the comment symbol (Fig. 3.5).



Рис. 3.5

Each scheme of the program must begin and end with the obligatory symbol "Terminator", in which the word "*Beginning*" is written at the entrance to the program, and the word "*End*" is written at the exit from the program. In the schemes of subroutines, the initial symbol "Terminator" indicates its "*Name*", and at the exit - "*Exit operator*" from the subroutine.

The text of the program (listing) in the algorithmic language is usually placed in the appendices of the explanatory note on sheets of A4 format without a

frame of the working field and without the main inscription.

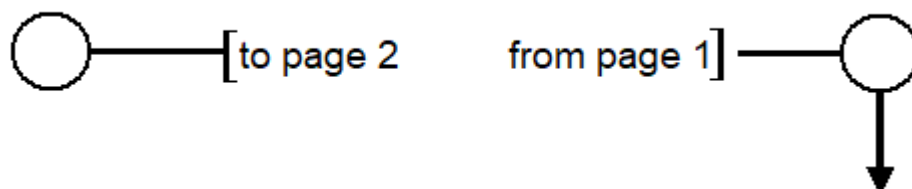
3.3. Preparation of the abstract of the work

The abstract is an abbreviated summary of the content of the diploma project with the main results of the development and conclusions.

The design of the abstract is similar to the design of the main text of the thesis. Page numbering is done separately from the thesis page numbering. Structural parts of the abstract are not numbered, their names are printed in capital letters symmetrically to the text.

The abstract is intended for a brief introduction to the diploma project. It should be short, informative and reflect the main results and conclusions of the diploma project.

The abstract is placed at the end of the diploma project, starting from a new page.

The abstract should contain:

- information about the scope of the diploma project: the number of drawing sheets, explanatory note pages, sections, illustrations, tables, appendices;
- the text of the abstract;
- a list of keywords.

The text of the essay reflects the information presented in the diploma project in the following sequence:

- topic, nature and purpose of the work;
- used methods (calculation, experimental, software, modeling, etc.), equipment (indicate which devices, control and measurement equipment) and software products;
- basic structural, technological and operational characteristics and indicators (indicate parameters of devices, devices and/or systems, developed programs);
- work results, their novelty and economic efficiency;

– recommendations on the use of the project results (if necessary, the place of implementation and the degree of use of the development, possible areas of application are indicated).

Information about the diploma project in the essay is presented concisely and clearly. In the text of the abstract, it is advisable to use standardized terminology and expressions that are used in scientific and technical documents; unusual, unconventional and slang terms and symbols should be avoided.

Keywords that are decisive for revealing the essence of the diploma project are placed after the text of the abstract. The list of keywords should contain from 5 to 15 words (phrases), printed in capital letters in the nominative case on a line separated by commas.

The student, completing the diploma project, must once again independently check its compliance with the established general requirements, which are listed in Appendix I, as well as with the regulatory and legal framework of the Higher Education Institution and Ukraine.

The student's compliance with the rules and policies of academic integrity is mandatory when preparing a diploma project.

4. DESIGN OF A MULTIMEDIA PRESENTATION

Presentation of the thesis is a mandatory component of its defense. An electronic or printed file contains visual material accompanying the speaker's speech. On the one hand, with the help of a presentation, the student presents the main theses of the project to the examination committee. On the other hand, he uses it as a "legal cheat sheet", because the information contained on the slides helps not to get confused, and reminds him of important dates, numbers and definitions.

The presentation should be high quality and professional in order to effectively convey information to the audience.

Designing a presentation for a thesis

You can make a presentation using presentation software such as PowerPoint, OpenOffice Impress, or others, with on-screen display.

It is recommended to choose a simple, but effective design. The presentation should only be a "background" for the oral presentation of the material and should not distract attention from the speaker. The commission should perceive the material, and not just look at the pictures on the screen.

In its finished form, the presentation should contain a concise statement of the most important stages of the project (topic, goal, tools, conclusions) and an illustrative series.

Visual elements of the presentation:

- tables;
- schemes;
- diagrams;
- maps;
- photographs;
- drawings;
- comparative facts;

- infographics.

Rules for making a presentation for a diploma

1. A concise presentation of the text in the form of lists, rules, schemes.
2. The main emphasis is on illustration.
3. Recommended number of slides: from 7 to 15.
4. Absence of any errors.
5. A single business style of graphic design.
6. Optimal performance time: 7-10 minutes.

The structure of the presentation for the thesis

A professional presentation of the project should contain the following main points.

1. Title of work.
2. Purpose, relevance and subject of research.
3. Review of the tools that were used.
4. Overview of the research process.
5. Assessment of intermediate results.
6. Conclusions.
7. Thank you for your attention.

General requirements for the presentation

The information in the slides is presented in the form of abstracts, not simple sentences. One slide should not be filled with too much information: no more than three or four blocks of information (facts, statistical data, definitions, conclusions, etc.) can be effectively perceived at one time. The level of perception of information depends on its location on the screen. The most important information is located in the upper left corner of the slide. It is easier to read information arranged horizontally, rather than vertically. The greatest effectiveness is achieved when the key points are displayed one on each slide. Placing a lot of small text on

the slide is unacceptable. During the presentation, it is unacceptable to read the text from the presentation, that is, the printed and spoken text must not duplicate each other.

Do not create bulky presentations, optimally - 12-17 slides (including mandatory ones), carefully select the template, text, graphics, taking into account the requirements.

It is necessary to follow a strict rule: the amount of text in presentations should not exceed 35%. All unnecessary text should be left either for oral presentation or replaced with illustrative material: graphs, diagrams, calculations, drawings, photographs, etc.

Requirements for the content of a multimedia presentation

Each slide should reflect one idea. The presentation should correspond to the report. The content of each piece of textual information should be logically complete, maximally informative, concisely and succinctly stated.

The presentation should have a certain structure, namely:

- title slide;
- introduction;
- the main part containing certain subdivisions;
- conclusions.

The first slide should contain the name of the university and the name of the graduation department. The topic of the work, the type of work (qualification, master's), the surname, first name, patronymic of the person performing the work, as well as the surname, first name, patronymic of the supervisor and his academic title should be indicated.

The relevance of the research should be noted **on the second slide**. Relevance should be determined by a number of arguments. The following standard clichés should be used:

Relevance of research

- ◆ *due to the attention of modern science to ...*
- ◆ *explained by the need for in-depth study*
- ◆ *related to research ...*
- ◆ *determined by the following provisions*
- ◆ *consists in*

The third slide is the purpose and tasks of your work.

The fourth and fifth slides are definitions of the main concepts that are considered in the work or the most important conclusions of a theoretical nature.

The sixth and seventh slides are the most important conclusions of a practical nature or the results of practical research.

The eighth and ninth slides are the student's personal contribution to the development of this problem.

The tenth slide is the main results or general conclusions. The degree of compliance of the work results with the assigned tasks.

The eleventh slide is the possibility of practical implementation/recommendation for use. The following standard clichés should be used:

In the future, the diploma project can be expanded due to ...

Further research is planned...

Further development is planned...

In the future, it is planned to implement...

The last slide is words of thanks to the chairman and members of the commission.

Be sure to number the slides in the upper right corner. To highlight information, you can use: frames, borders, filling, arrows.

To confirm the plausibility of your research, use illustrative material in your presentation: drawings, diagrams, diagrams, photos, etc.

The best for perception is a white background. Using fill, check how readable your slides will be. The materials are placed on the slides so that free

fields remain from the edges of the slide.

Text requirements

The text should consist of short words and simple sentences. Mandatory observance of the accepted rules of spelling, punctuation, abbreviations and rules of text design (absence of period in headings, etc.). Verbs must be in the same tense.

The arrangement of information on the slide is mainly horizontal, from top to bottom along the main diagonal. The most important information should be located in the center of the slide. If the slide shows graphic material, the inscription should be located below it. It is advisable to format the text by width; do not allow "torn" edges of the text. Headings should attract attention and summarize the main points of the slide.

Slide titles are written in capital letters. When displaying textual information (goals, main provisions, etc.) on a slide, the following requirements should be observed: a line should contain 6–8 words, and there should be 8–12 lines in total on the slide. It is necessary that the text is clearly visible. The font size should not be small (the recommended minimum is 22 pt font). Omit the italics.

Lists should be used only where they are needed. Large lists and tables should be divided into 2 slides.

It is recommended to use non-serif fonts for presentations (they are easier to read): Arial, Verdana.

The ratio of the thickness of the main strokes of the font to their height is approximately 1:5, the most understandable ratio of the size of the font to the spaces between letters: from 1:0.375 to 1:0.75. The distance between lines within a paragraph is 1.5, and between paragraphs - 2 spaces. A single font style is set for the entire presentation.

Requirements for the visual and sound range

Animation should not be intrusive. It is not allowed to accompany the appearance of the text with sound effects.

It is not recommended to choose animation effects for titles, especially such as "Rotation", "Spiral", etc. In information slides, animation of objects is allowed only if it is necessary to display, for example, changes in electrical characteristics, and if the sequence of appearance of animated objects corresponds to the sequence of processes, phenomena, etc.

Animations are used to emphasize, highlight some key features, separate the results of one experiment from another, etc.

Design requirements

All presentation slides should be in the same style. Use psychologically comfortable tones for the background of the slide, the background should be an element of the background (second) plan: highlight, shade, emphasize the information placed on the slide, but not hide it. It is recommended to use no more than three colors on one slide: one for the background, the second for the headings, and the third for the text. The best combination of font and background colors is white on dark blue, black on white, yellow on blue.

Slides should not be too bright. For the background, you should choose colder tones (blue or green), but if you are not sure about the quality of the lighting of the audience where the presentation will take place, it is better to choose a white background. The text should be clearly visible. The color scheme should be the same for all slides.

5. RECOMMENDATIONS REGARDING THE REPORT

The report should reveal the essence and theoretical significance of the results of the work carried out.

Structurally, the report can be divided into three parts:

1) The first part of the report essentially repeats the introduction of the bachelor's project. It is necessary to announce the relevance of the chosen topic, the description of the scientific problem and the main goals of the research. It is also necessary to indicate the methodology by which the research was carried out, as well as to characterize the composition and general structure of the master's thesis.

2) The second part of the report, the largest part in terms of volume, which consistently characterizes each section of the master's thesis. At the same time, special attention is paid to the results and conclusions. Critical comparisons and evaluations are also noted.

3) The final part of the report, which is based on the text of the conclusions of the bachelor thesis. Here it is worth listing the general conclusions (without repeating the generalizations already said).

During the defense, auxiliary materials in the form of a presentation or graphic material (diagrams, tables, graphs), which are necessary to prove the provisions and justify the conclusions drawn, must be used.

During the defense, it is especially important that the speaker's speech is clear, grammatically correct, legible and persuasive. In addition, the report should be expressive, and this depends on the pace, volume and intonation. If you speak hastily, without clearly pronouncing the end of the words, or, on the contrary, very quietly and indistinctly, then the quality of the speech deteriorates. A calm, unhurried manner of presentation always impresses listeners.

Writing the text of the report is mandatory. The approximate volume of the text is 4-5 pages, which are printed in 2 spaces (approximately 1900 characters per page).

The style of the report should be as close to conversational as possible.

It is not allowed to read the text of the report.

It is necessary to report loudly, confidently, so that the members of the commission understand that the speaker has a good command of the material. It will not hurt if on the eve of the defense there will be a rehearsal of the report in front of friends or work colleagues. Answers to the questions of commission members and attendees should be concise, clear and well-argued. If references to the text of the master's thesis are possible, then they must be made. Questions may concern both the content of the report and the explanatory note. General and theoretical questions may be asked in order to determine the student's level of preparation.

6. ORGANIZATION OF DEFENSE OF THE DIPLOMA PROJECT

The diploma project is defended publicly at a meeting of the examination commission (EC).

The issue of admission of a student to the defense of a diploma project is decided by the head during the procedure of admission of a diploma project to defense at a meeting of the department. The supervisor prepares a written feedback on the diploma project, in which he notes the relevance, theoretical level and practical significance, if available - scientific novelty; depth of development; correctness and validity of conclusions; the student's readiness to perform independent practical work and acquire the full range of relevant competencies and learning program outcomes provided for by the educational and professional program and the standard of higher education. A sample of approximate questions that appear in the supervisor's response to the diploma project is given in Appendix J.

A week before the defense, the diploma project is submitted to the department together with the review of the scientific supervisor. The department organizes the review of the diploma project and at its meeting makes a decision on the admission of the diploma project to defense. After that, diploma projects with accompanying documentation are sent to the EC for protection. A sample of approximate questions that are covered in the review of the diploma project is given in Appendix K.

The following documents are submitted to the EC to defend the diploma project:

- an explanatory note with the signatures of the student, supervisor and head of the department;
- graphic material (drawings and posters);
- manager feedback with evaluation;
- review with assessment;

- if necessary, additional materials characterizing the student's scientific and technical achievements in the form of articles, reports, patents, models, software products, implementation results. A sample certificate on the reality of the project is given in Appendix L.

During the preparation for the defense of the diploma project, students are required to prepare a short report for 7-10 minutes. At the beginning of the speech, it is recommended to briefly characterize the relevance of the topic and the object of the study. After that, it is advisable to proceed to the teaching of the main content of the work: choose 2-3 key questions that must be presented according to this scheme - the current situation (shortcomings revealed during research and analysis), measures proposed to eliminate the shortcomings, the likely effectiveness of the proposed recommendations. During the report, it is necessary to use illustrative materials - drawings, posters, presentations, explaining their content to the EC members and those present.

The supervisor's presence at the defense of the diploma project is mandatory.

After the report, students answer the questions of EC members, as well as everyone present at the defense. At the end of the defense, the speaker is given the floor to respond to the supervisor's and reviewer's comments, if there are such comments.

The duration of the defense of one diploma project is up to 30 minutes.

The order of protection is as follows:

- student report;
- answers to the questions of the members of the examination commission;
- announcement of manager feedback and reviews;
- responses to remarks made in the manager's feedback and reviews.

During the defense of the diploma project, each member of the EK will evaluate the quality of the diploma project and the quality of its defense according to the rating system for the evaluation of qualification works (RS). After the end of the defense, at a closed meeting of the EC, the average score of the evaluation by the members of the EC of the quality of the diploma project and the quality of its

defense is calculated, which is entered into the protocol, and further in accordance with the Regulation on the system for evaluating the results of training of students of higher education in KPI named after Sikorskyi's speech is transferred to the evaluation, which is also included in the protocol and announced to the students by the head of the EC.

Based on the results of the positive defense, the student is awarded the educational qualification "Bachelor of Electronics" and a state diploma of the established model is issued.

REFERENCES

1. Pro vyshchu osvitu: Zakon Ukrainy vid 01.07.2014 r. № 1556-VII. Data onovlennia:, chynnyi, potochna redaktsiia vid 24.03.2024, URL:<http://zakon2.rada.gov.ua/laws/show/1556-18> (data zvernennia: 05.05.2024).
2. Standart vyshchoi osvity Ukrainy: pershyi (bakalavrskyi) riven vyshchoi osvity, haluz znan 17 «Elektronika ta telekomunikatsii», spetsialnist 171 «Elektronika». [Chynnyi vid 2018-11-03, vneseni zminy 2021-11-15]. Kyiv: Ministerstvo osvity i nauky Ukrainy, 2018. 20 p. URL:<https://mon.gov.ua/storage/app/media/vishcha-osvita/zatverdzeni%20standarty/12/21/171-elektronika-bakalavr-VO-zatv.stand.01.11.pdf>
3. Regulations about the examination commission and attestation of higher education applicants in Igor Sikorsky Kyiv Polytechnic Institute (enacted by order No. 7/178 dated October 1, 2020 (with changes by order No. HY/71/2021 dated April 19, 2021). 23 p. URL: https://osvita.kpi.ua/sites/default/files/downloads/Regulations_EC_certification.pdf
4. DSTU 3008:2015 Zvity u sferi nauky i tekhniky. Struktura ta pravyla oformliuvannia. [Chynnyi vid 2015-06-22]. Kyiv, 2015. 31 s. (Informatsiia ta dokumentatsiia). URL:https://science.kname.edu.ua/images/dok/derzhstandart_3008_2015.pdf
5. DSTU 8302:2015 Bibliohrafichne posylannia. Zahalni vymohy ta pravyla skladannia. [Chynnyi vid 2016-07-01]. Vyd. ofits. Kyiv, 2016. 20 s. (Informatsiia ta dokumentatsiia). URL:<http://lib.pnu.edu.ua/files/dstu-8302-2015.pdf>
6. DSTU 3582:2013 Bibliohrafichnyi opys. Skorochennia sliv i slovopoluchen ukrainskoiu movoiu. Zahalni vymohy ta pravyla. [Chynnyi vid 2013-08-22]. Vyd. ofits. Kyiv, 2014. 17 p. (Informatsiia ta dokumentatsiia). URL:https://lib.zsmu.edu.ua/upload/intext/dstu_3582_2013.pdf
7. DSTU 3321:2003. Systema konstruktorskoj dokumentatsii. Terminy ta vyznachennia osnovnykh poniat. [Chynnyi vid 2003-12-08]. Kyiv, 2005. 55 s. URL:<http://www.tsatu.edu.ua/ettp/wp-content/uploads/sites/25/3-dstu->

[33212003.pdf](#)

8. DSTU HOST 2.104:2006. Yedyna systema konstruktorskoi dokumentatsii. Osnovni napysy. [Chynnyi vid 2006-12-26]. Vyd. ofits. Kyiv, 2005. 23 p. URL:https://vsegost.com/Catalog/97/974.shtml#google_vignette

9. DSTU HOST 2.702:2013 Edyna systema konstruktorskoi dokumentatsii. Pravyla vykonannia elektrychnykh skhem. [Chynnyi vid 2014-09-01]. Vyd. ofits. Kyiv, 2014. 29 p. URL:https://dnaop.com/html/61479_2.html.

APPROXIMATE THEME OF THE DIPLOMA PROJECTS

1. The inverter is led by a network with a control system.
2. Inverter with phase-to-phase single-stage switching.
3. Rectifier with power factor correction.
4. Multiphase rectifier with a microprocessor control system.
5. Voltage stabilizer.
6. Pulse width converter.
7. Variable load generator.
8. Variable voltage regulator with voltage boost.
9. Single-phase power factor corrector
10. Digital filter of sound frequencies.
11. Pulse generator.
12. Autonomous power supply generator.
13. Microprocessor control system for room energy saving.
14. Electrical energy converter control system.
15. Information display device.
16. Local object power supply control unit.
17. Power supply system control module.
18. Power factor correction device.
19. Correlation coder.
20. Multifunctional household electronic device.
21. Microcontroller protection system.
22. Battery charger.
23. Temperature maintenance device.
24. Programmable digital generator.
25. Relay protection device.
26. Information resource on discipline.

Appendix B

**APPROXIMATE STRUCTURE OF THE DIPLOMA PROJECT BY
VOLUME**

№	Name of part of the project	Number of pages
1.	Project statement	1
2.	Title page	1
3.	Task	1
4.	Abstract	1 - 2
5.	Content	1 - 2
6.	Introduction	2 - 3
7.	Chapter 1. Selection of a technical solution	10 - 12
8.	Chapter 2. Description of development	15 - 17
9.	Chapter 3. Calculation part	18 -20
10.	Chapter 4. Results of simulation and/or experiment	8 - 10
11.	Conclusions and recommendations	2 - 3
12.	Reference	2 – 3
13.	Appendices (tables, programs, charts, graphs)	
14.	Abstract in a foreign language	8 - 10
	Together	60 - 70

NATIONAL TECHNICAL UNIVERSITY OF UKRAINE
«IGOR SIKORSKY KYIV POLYTECHNIC INSTITUTE»
Faculty of electronics
Department of electronic devices and systems

Admitted to the defense
 Head of Department
 _____ Evgen VERBYTSKY
 « ___ » June _____ 2024 p.

Diploma project
for a bachelor's degree
under the educational and professional program "Electronic components and systems" specialty 171 "Electronics"
on the subject: "*Theme*"

Performed by:
 IV year student, group DS-02
Full Name

Supervisor: _____
Position, scientific degree, academic rank,
Full Name

Reviewer: _____
Position, scientific degree, academic rank,
Full Name

Consultant from norm control _____
Position, scientific degree, academic rank,
Full Name

I certify that in this diploma project there are no borrowings from the works of other authors without appropriate references.
 Student _____

**NATIONAL TECHNICAL UNIVERSITY OF UKRAINE
«IGOR SIKORSKY KYIV POLYTECHNIC INSTITUTE»**

Faculty of electronics

Department of electronic devices and systems

Level of higher education - first (bachelors)

Specialty - 171 "Electronics"

Educational and professional program " _____ "

APPROVED
Head of Department

_____ Evgen VERBYTSKY
« ____ » _____ 2024

TASK
for the student's diploma project
Full Name

1. Project topic _____

project Supervisor _____

Surname, first name scientific degree, academic rank

approved by order of the university dated « ____ » _____ 2024 year No. _____

2. Deadline for the student to submit the project _____

3. Input data for the project _____

4. Contents of the explanatory _____

CONTENT

	Cт.
INTRODUCTION.....	4
1. DEVELOPMENT OF THE STRUCTURAL DIAGRAM OF THE RECTIFIER	6
1.1. Development of the structural scheme of the power unit.....	6
1.2. Development of the structural diagram of the control system.....	9
2. DEVELOPMENT OF THE SCHEME OF THE ELECTRICAL PRINCIPAL POWER UNIT.....	15
2.1. The principle of operation of the power unit.....	15
2.2. Calculation and selection of elements of the scheme of the power unit.	22
3. DEVELOPMENT OF THE SCHEME OF THE ELECTRICAL PRINCIPAL CONTROL SYSTEM.....	27
3.1. Selection of the basic electrical circuit of the control system.....	27
3.2. The principle of operation of the control system.....	30
3.3. Calculation of parameters for software.....	38
3.4. Calculation and selection of elements of the synchronization scheme....	45
3.5. Calculation and selection of elements of the output amplifier.....	49
CONCLUSIONS AND RECOMMENDATIONS.....	62
REFERENCES	
Addition. Program listing	

					DP DC02. 003. 001. EN					
Con	Sheet	Name	Signate	Date	The subject of the diploma project. Explanatory note			Letter	Sheet	Sheets
Develope										
Check										
N.cont										
Confir					<i>"Igor Sikorsky KPI", FEL, EPS, gr. DS-02</i>					

1. STANDBY POWER SUPPLY SYSTEMS

1.1 Power sources with a diesel generator

The current level of saturation with electrical equipment in ordinary and special premises of buildings and objects determines high requirements for the quality and reliability of electricity. Uninterruptible power supply systems are built, as a rule, on the basis of the inclusion of several energy sources in the general scheme (Fig. 1.1), where (WG - wind generator, PB - photo battery, DG - diesel generator, B - battery, S - switch, PC – power converter, L – load) [1].

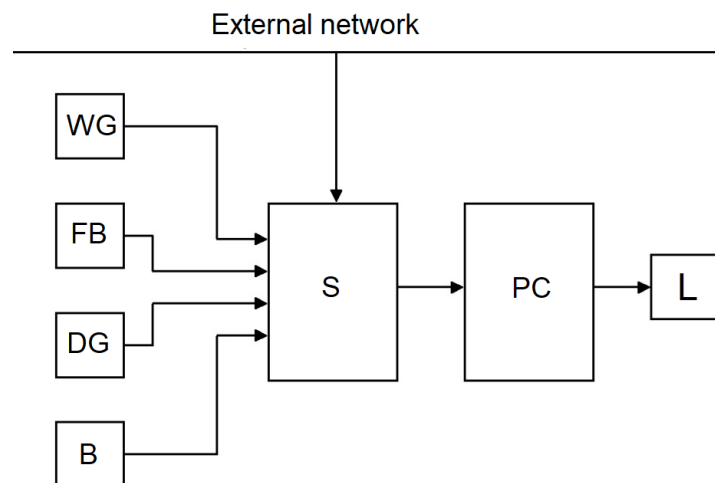

Fig. 1.1. Uninterruptible power supply system

1.1.1 Modeling of diesel generator parameters

The power produced by the diesel generator is determined by the product of the moment on the shaft M and the engine speed ω : $P = M \cdot \omega$.

The transient process of power increase is described by a differential equation of the first order [5].

$$\alpha \frac{dP(t)}{dt} = bP_m - P(t). \quad (1.1)$$

Appendix H

Designation	Name	Qty	Notes			
<u>Resonators</u>						
BQ1	PG – 05 – 14ET – 16000 кГц – БВ – В					
BQ2	PG – 05 – 14ET – 6000 кГц – БВ – В					
<u>Capacitors</u>						
C	1206 – NPO – 50V – 30 пФ ±10%	2				
C	1206 – X7R – 50V – 0,1 мкФ ±10%	10				
C13...C19	SMD – B – 20V – 10 мкФ ±20%	7				
C32	LXV – 50V – 25 мкФ ±5%	1	“CHEMI – CON”			
		1				
<u>Microcircuits</u>						
DD1	AT49F002AN – 55TI	1	Atmel			
DD2,DD3	AduM1400 BRW	2	Analog Devices			
DD4	ADSP – 2185 BST – 133	1	Analog Devices			
		2				
<u>Diodes</u>						
VD1,VD2	15MQ040	2				
VD3,VD4	SM4003	2				
<u>Resistors</u>						
R1...R3	1206 – 0,25W – 4,7 кОм ±5%	3				
R4...R15	1206 – 0,25W – 10 кОм ±5%	12				
DP.DS02.012.001 LE3						
Con	Sheet	Name	Signate	Date		
Develop						
Check						
N.contr.						
Solidifi						
The subject of the diploma project. List of elements				lit	Sheet	Sheets
					1	3
				<i>"Igor Sikorsky KPI", FEL, EPS, gr. DS-02</i>		

**GENERAL REQUIREMENTS
to the diploma project**

Volume of diploma project	60 – 70 pages of computer typing text with 1.5 spacing Font - Times New Roman Size – 14 pt., without Appendixes
Form	Hardcover shitting
Language	Ukrainian, English
Structure	Introduction Technical chapters Conclusions and recommendations References (At least 20-25 sources) Appendices Abstract
Mandatory availability	tables, schemes, graphs, diagrams, formulas
Mandatory use	Computer programs for calculations and design of work
To be admitted to protection, you must:	<ol style="list-style-type: none"> 1. External review of work 2. Feedback from the scientific supervisor 3. Diploma project completed and signed by the supervisor 4. Graphic material – 3 sheets

RESPONSE
of supervisor of the diploma project
first (bachelor) level of higher education

performed by the topic: _____

by the student _____
(Name, FAMILY NAME)

(text of review)

the review is written in an arbitrary form with an indication of:

the main goal of the diploma project, in the interests of or at the request of which organization it was carried out (as part of the research work of the department, enterprise, scientific research institute, etc.);

compliance of the completed project with the task;

degree of independence in the implementation of the project;

level of preparedness graduate to make modern decisions;

the ability to analyze the necessary literary sources, to make correct (engineering, scientific) decisions, to carry out physical or mathematical modeling, to process and analyze the most important theoretical and practical results (participation in conferences, seminars, registration of patents, publication in scientific journals, etc.);

general evaluation of the completed project, compliance with the requirements of the educational program;

other issues that characterize the professional qualities of the graduate.

Information on compliance with the rules of academic integrity and the anti-plagiarism policy must be noted.

Supervisor
of the diploma project

(Position, Scientific degree, Academic title)

(Sign)

(Name, FAMILY NAME)

REVIEW
of the diploma project
first (bachelor) level of higher education

performed by the topic: _____

by the student _____

(Name, FAMILY NAME)

(text of review)

the review is written in an arbitrary form with an indication of:

compliance of the project with the approved topic and task for diploma design;

topicality of the topic;

reality of the project (its implementation on the order of enterprises, organizations, according to the scientific topic of the department, research institutes, etc.);

depth of technical and economic justification of decision-making; degree the use of modern achievements of science, technology, and engineering;

the originality of the decisions made and the results obtained; the availability and completeness of the experimental (physical or mathematical) decisions made;

the quality of the execution of the explanatory note, compliance of the drawings with the requirements of DSTU, ESKD;

possibilities of implementation of project results;

shortcomings of the project;

evaluation of the project on a 100-point and national scale and the possibility of awarding the graduate with the appropriate qualification (formulation according to the curriculum).

Reviewer

(Position, Scientific degree, Academic title)

(Sign)

(Name, FAMILY NAME)

Stamp of enterprise or organization, where the reviewer employed *(only for external reviewers)*.

SAMPLE CERTIFICATE ABOUT THE REALITY OF THE PROJECT

(enterprise form)

Heads of the
examination commission

Diploma project of a student of the group _____ Faculty of Electronics

(First Name Last Name)

on the topic _____

performed in the interests of our organization and is real.

The expected annual economic effect from the implementation of the results of this project is _____.

The project materials are made in accordance with the regulatory documents in force at our company.

This document is not a basis for the parties to present mutual financial claims.

The explanatory note to the diploma project does not contain information marked as confidential or for official use, as well as materials that are subject to licensing and (or) patenting and are not allowed to be published in the open press.

Seal

Signature